

PUBLIC AUCTION

(6) TAX-DEEDED PROPERTIES IN CONCORD, NH Single Family Home · Vacant Residential Lot (3) Mobile Homes in Parks & (1) On Land



Friday, January 26 at 2:00 PM (Registration from 1:00 PM)

Sale Location: CITYWIDE COMMUNITY CENTER, 14 Canterbury Road, Concord, NH

ID#24-113 · We have been retained by the City of Concord to sell at PUBLIC AUCTION these (6) properties which were acquired by Tax Collector's Deed. These properties appeal to first time buyers, investors and abutters!

SALE # 1: 5 Lake Street (Tax Map 393, Lot Z-7)



Conventional style home located on a 0.23± acre lot offering 2,297± SF GLA, 10 RMS, 5 BR, & 2 BA · 1900 built 1 ½ story home features include farmers porch, attached 1-car garage, wood clapboard siding, deck to rear, and FHW/Gas heat · Served by public water and sewer · Assessed value: \$332,100. 2023 Taxes: \$8,920. **DEPOSIT: \$5,000**

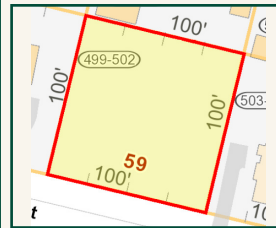

SALE # 2:
59 Hobart Street
(Tax Map 201, Lot P-54)
Vacant 0.22± acre lot located in a nice neighborhood just off Rt. 3. Lot is cleared and flat, and is served by public water and sewer · Assessed value: \$82,900. 2023 Taxes: \$2,416. **DEPOSIT: \$5,000**

SALE # 3: 216 Pembroke Road (Tax Map 622, Lot Z-8)

1972 Manufactured home located on a 0.85± acre lot just off Rt. 106 · Home consists of 876± SF GLA, 4 RMS, 2 BR, & 1 BA · Features include front deck, rear porch, detached garage, and FHA/Oil heat · Served by public water and sewer · Assessed value: \$134,300. 2023 Taxes: \$3,607. **DEPOSIT: \$5,000**



SALE # 4:
69 Manchester St, #7
(Tax Map 781, Lot Z-5-7)
1995 built Manufactured home located in mobile home park just off Rt. 3 close to I-93 · Home offers 924± SF GLA, 4 RMS, 2 BR, & 2 BA · Features include vinyl siding, paved parking, & FHA/Oil heat · Served by public water & sewer · Assessed value: \$53,100. 2023 Taxes: \$1,426. Park rent \$375/month **DEPOSIT: \$2,500**



SALE # 5: 13 Monarch Drive (Tax Map 301, Lot Z-27-88)

1980 built manufactured home located in Concord Terrace MHP. Home offers 784± SF GLA, 4 RMS, 2 BR, & 1 BA · Features include detached shed, side deck, paved parking & FHA/Oil Heat · Assessed value: \$15,200. 2023 Taxes: \$408. Park rent \$545/month. **DEPOSIT: \$2,500**



SALE #6: 20 Rex Drive (Tax Map 301, Lot Z-27-28)

1976 built manufactured home located in Concord Terrace MHP. Home offers 840± SF GLA, 4 RMS, 2 BR, & 1 BA · Features include detached shed, front deck, enclosed porch and FHA/Oil Heat · Assessed value: \$14,100. 2023 taxes: \$379. Park rent \$545/month. **DEPOSIT: \$2,500**



7.5% BUYERS PREMIUM PAYABLE TO AUCTIONEER DUE AT CLOSING

Auctioneer's Note: Some properties are occupied, the City of Concord will take no steps to remove occupants. Eviction process will be the responsibility of the successful buyers.

TERMS: Non-refundable deposits by cash, certified check, bank check, or other form of payment acceptable to the City of Concord at time of sale, balance due within 30 days. **SALES ARE SUBJECT TO CITY CONFIRMATION. THE CITY OF CONCORD RESERVES THE RIGHT TO REJECT ANY AND ALL BIDS.** Conveyance by Quitclaim Deed. All properties sold "as is, where is" subject to all outstanding liens, if any. Other terms may be announced at time of sale.

All information herein is believed but not warranted to be correct. All interested parties are advised to do their own due diligence relative to the buildability/non-buildability of any lot and all matters they deem relevant.

PLOT PLANS, PHOTOS, BROCHURE, AND MORE DETAILS ARE AVAILABLE ON OUR WEBSITE



JSJ Auctions
SINCE 1982



45 Exeter Road, Epping, NH 03042, NH Lic. #2279
603-734-4348 • www.jsjauctions.com

AGREEMENT AND DEPOSIT RECEIPT

THIS AGREEMENT made this 26 day of January, 2024 by and between the City of Concord, a municipal corporation organized under the laws of the State of New Hampshire, having a principal place of business at 41 Green Street, Concord, New Hampshire, 03301 (hereinafter referred to as the SELLER) AND the BUYER,

having an address of _____

If mailing address is different please state: _____

WITNESSETH: The SELLER agrees to sell and convey, and the BUYER agrees to buy:

PROPERTY DESCRIPTION:

SELLER’S right, title and interest in certain land with the buildings and improvements thereon, if any, located in Concord, Merrimack County, New Hampshire, known as:

Being Map: _____ Lot: _____

SELLING PRICE, DEPOSIT AND PAYMENT:

The selling price is _____ (\$ _____)
payable as follows:

A. The BUYER’s deposit, the receipt of which is hereby acknowledged, in the sum of _____ (\$ _____) for the home; lot to be held in escrow by Seller.

B. The balance of the selling price in the amount of _____ (\$ _____)

Shall be paid on the date of transfer of title, by cash or certified bank check

In the event there is any dispute relative to the deposit monies held in Escrow, the SELLER may, in its sole discretion, pay said monies into the Clerk of the Court of proper jurisdiction in an Action of Interpleader and provide each party with notice thereof at the address stated herein. Should for any reason the funds for the deposit be returned as insufficient, then at the option of the Seller, this contract shall be null and void and the parties shall have no further recourse with regards to this Agreement.

BUYER'S PREMIUM DUE AUCTIONEER: The selling price does not include the BUYER's premium of seven and one half (7.5%) percent of the purchase price, due to the Auctioneer at closing. BUYER'S premium is calculated as follows:

Selling Price \$ _____ @ 7.5% = _____.

Payment of such an amount by the BUYER in accordance with the previous sentence, by cash or certified bank check, at closing is a prior condition of the SELLER'S obligation to convey title. This BUYER'S premium is in addition to the purchase price and is payable directly to the Auctioneer.

DEED: The SELLER agrees to furnish, at its own expense, a duly executed Quitclaim Deed of the property.

POSSESSION AND TITLE: The property is sold in its "AS IS, WHERE IS" condition without any warranty as to its condition whatsoever, subject to all tenants and rights of use or possession, outstanding municipal charges for sewer, water or betterment assessments/connection charges for the same and other matters of record, if any, including State and Federal tax liens having priority over the Town's tax lien or title.

TRANSFER OF TITLE: The transfer of title shall occur within thirty (30) days from the date of this Agreement, TIME BEING OF THE ESSENCE, at the Concord City Hall, Collections Office located at 41 Green Street, Concord, New Hampshire or at any other place to be mutually agreed upon by the parties.

TITLE: If the BUYER desires an examination of title, BUYER shall pay the cost thereof. BUYER acknowledges that title be transferred by Quitclaim Deed and BUYER'S title shall be subject to matters of record and as described in the section entitles POSSESSION AND TITLE above.

LIQUIDATED DAMAGES: If the BUYER shall default in the performance of his/her obligations under this Agreement, the amount of the deposit and any additional deposit given by BUYER may, at the option of the SELLER, become the property of the SELLER as reasonable liquidated damages. Further, all of the BUYER'S right and interest in and to the Agreement shall, without notice or further consideration, be assigned to SELLER. Upon BUYER'S default or failure to close, SELLER reserves the unqualified right to sell the property to the next highest bidder.

RADON GAS AND LEAD PAINT NOTIFICATION: Pursuant to the requirements of New Hampshire RSA 477:4-a, BUYER acknowledges that it has received the following notification.

- (a) "Radon Gas. Radon gas, the product of decay of radioactive material in rock may be found in some areas of New Hampshire. This gas may pass into a structure through the ground or through water from a deep well. Testing can establish its presence and equipment is available to remove it from the air or water."
- (b) "Lead Paint. Before 1977, paint containing lead may have been used in structures. The presence of flaking lead paint can present a serious health hazard, especially to young children and pregnant woman. Tests are available to determine whether lead is present."

BUYER'S acknowledgements contained in this paragraph shall survive the transfer of title and possession.

PRIOR STATEMENTS: All representations, statements, and agreements heretofore made between the parties hereto are merged in this Agreement, which alone fully and completely expresses their respective obligations. This Agreement is entered into by each party after opportunity for investigation, neither party relying on any statements or representation not embodied in this Agreement made by the other or on his behalf. This Agreement shall not be altered or modified except by written agreement signed and dated by both the SELLER and the BUYER.

ADDITIONAL PROVISIONS:

WITNESS: the signatures of the above parties on the dates as noted below.

THE City of Concord

BUYER

By: _____

By: _____

Dawn K Enwright, CTC

Its: City Treasurer/Tax Collector

Its: _____

(Title if other than individual)

Duly Authorized

Duly Authorized

Witness

Witness

216 PEMBROKE RD

PID 9042

Map ID 622/Z 8 / / /
Bldg # 1

Bldg Name
Sec # 1 of 1

Card # 1 of 1

State Use 1030
Printed 10-13-2023 11:14:07 AM

CURRENT OWNER		TOPO	UTILITIES	STRT / ROAD	LOCATION	CURRENT ASSESSMENT				CONCORD, NH					
CYR JEFFREY B & JEAN B		2 Above Street	1 All Public	1 Paved	2 Suburban	Description	Code	Appraised	Assessed						
		5 Steep				RESIDNTL	1030	17,700	17,700						
216 PEMBROKE RD		SUPPLEMENTAL DATA				RES LAND	1030	91,000	91,000						
CONCORD NH 03301-5756		Alt Prcl ID 111 2 11				RESIDNTL	1030	25,600	25,600						
		Tract # Tract # Tract # Tract # Tract #				Total		134,300	134,300						
RECORD OF OWNERSHIP		BOOK/PAGE	SALE DATE	Q/U	VI	SALE PRICE	VC	PREVIOUS ASSESSMENTS (HISTORY)							
CYR JEFFREY B & JEAN B		2674 0984	06-29-2004	U	I	75,000	40 1N	Year	Code	Assessed	Year	Code	Assessed		
FULLER FREDERICK & SHAREN TRSTS		1989 0379	06-05-1995	U	I	300,000	21 1U	2023	1030	17,700	2022	1030	17,700		
FULLER FREDERICK & SHAREN TRSTS		1989 0375	04-18-1995	U	I	20,000	21 1U		1030	91,000		1030	91,000		
GROTON JAMES		1979 1746	01-23-1995	U	I	18,500	51 1N		1030	25,600		1030	25,600		
COLBETTS REALTY INC		1908 1176	02-12-1993	U	I	131,048	51 1L	Total		134,300	Total		134,300		
EXEMPTIONS		OTHER ASSESSMENTS						This signature acknowledges a visit by a Data Collector or Assessor							
Year	Code	Description	Amount	Code	Description	Number	Amount	Comm Int							
Total		0.00								APPRAISED VALUE SUMMARY					
Nbhd		Nbhd Name		B		Tracing		Appraised Bldg. Value (Card) 17,700							
B114								Appraised Xf (B) Value (Bldg) 0							
								Appraised Ob (B) Value (Bldg) 25,600							
								Appraised Land Value (Bldg) 91,000							
								Special Land Value 0							
								Total Appraised Parcel Value 134,300							
								Valuation Method C							
								Total Appraised Parcel Value 134,300							
BUILDING PERMIT RECORD								VISIT / CHANGE HISTORY							
Permit Id	Issue Date	Type	Amount	Insp Date	% Com	Date Comp	Comments	Date	Id	Type	Is	Cd	Purpost/Result		
								09-19-2005	MH			00	Measur+Listed		
								07-27-2005	SC			01	Exterior List		
								05-05-2003	BM			01	Exterior List		
								03-02-1990	LL						
								05-03-1989	TS	X		04	Measur/Vac/Boarded up		
LAND LINE VALUATION SECTION															
B	Use Code	Description	Zone	Land Units	Unit Pric	Infl Fctr	S I	Cond	Nbhd	Nbhd Adj	Notes	CU Cond	Special Pricing	Adj Unit P	Land Value
1	1030	MANUF HOME	IN	37,144 SF	1.86	1.1500	4	0.80	0114	1.430	TOPO		0	2.45	91,000
Total Card Land Units				0.85 AC	Parcel Total Land Area				0.85	Total Land Value				91,000	

VISION

CONSTRUCTION DETAIL			CONSTRUCTION DETAIL (CONTINUED)		
Element	Cd	Description	Element	Cd	Description
Style:	76	Single Wide			
Model:	02	Mobile Home			
Grade:	03	Average			
Stories:	1	1 Story			
Occupancy	1				
Exterior Wall 1	27	Pre-finish Metl			
Exterior Wall 2					
Roof Structure:	03	Gable/Hip			
Roof Cover	03	Asph/F Gls/Cmp			
Interior Wall 1	04	Plywood Panel			
Interior Wall 2					
Interior Flr 1	14	Carpet			
Interior Flr 2					
Heat Fuel	03	Gas			
Heat Type:	04	Forced Air-Duc			
AC Type:	01	None			
Total Bedrooms	02	2 Bedrooms			
Total Bthrms:	1				
Total Half Baths	0				
Total Xtra Fixtrs					
Total Rooms:	4				
Bath Style:	02	Average			
Kitchen Style:	02	Modern			
Trend					
CONDO DATA					
Parcel Id		C	Owne	0.0	
			B	S	
Adjust Type	Code	Description	Factor%		
Condo Flr					
Condo Unit					
COST / MARKET VALUATION					
Adj Base Rate			60.01		
Undeprec. Value			59,049		
Net Other Adj			0		
RCN			59,049		
Year Built			1972		
Depreciation Code			P		
Depreciation %			70		
Functional Obsol			0		
External Obsol			0		
Nbhd Factor			1.000		
Condition					
Condition %					
Percent Good			30		
RCNLD			17,700		

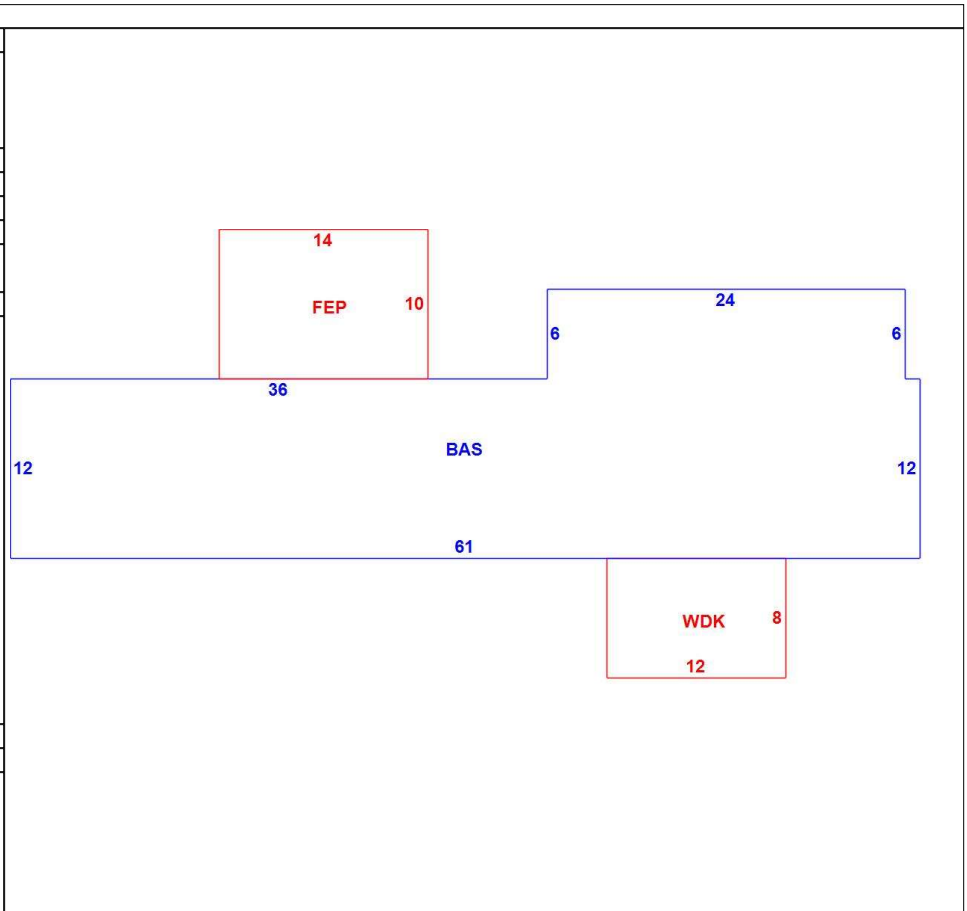

OB - OUTBUILDING & YARD ITEMS(L) / XF - BUILDING EXTRA FEATURES(B)										
Code	Description	L/B	Units	Unit Price	Yr Blt	Cond. Cd	% Gd	Grade	Grade Adj.	Appr. Value
FGR2	GARAGE-GO	L	1,260	29.00	1990		70		0.00	25,600

BUILDING SUB-AREA SUMMARY SECTION						
Code	Description	Living Area	Gross Area	Eff Area	Unit Cost	Undeprec Value
BAS	First Floor	876	876	876	60.01	52,568
FEP	Porch, Enclosed, Finished	0	140	98	42.01	5,881
WDK	Deck, Wood	0	96	10	6.25	600
Ttl Gross Liv / Lease Area		876	1,112	984		59,049

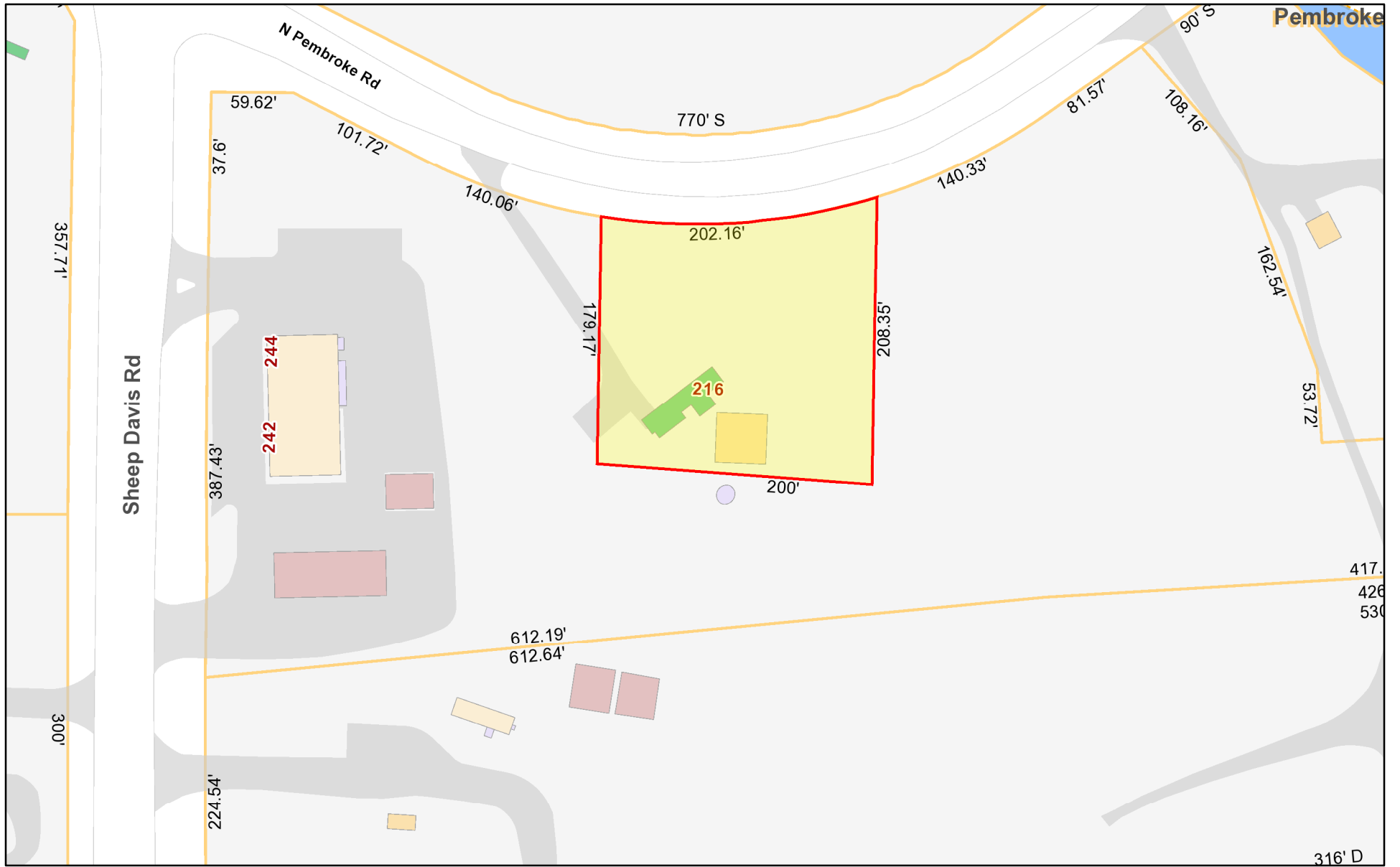

October 23, 2023

